

RECENT DEVELOPMENTS IN HELICOPTER NOISE REDUCTION

Harry Sternfeld Jr.
The Boeing Vertol Co.
Philadelphia, Pennsylvania, U.S.A.

Abstract

This paper reports on research activities directed at understanding and reducing interior and exterior noise of modern helicopters. Impending regulatory criteria for external noise are discussed, along with some of the newer understandings of the sources of rotor noise. The effect of rotor design on generated noise and methods for reducing the noise are presented. The paper also explains the application of finite element analytical techniques to optimizing the dynamic response of helicopter transmissions in order to minimize interior noise.

Introduction

The helicopter industry has been experiencing a dramatic conversion from a market which was almost completely dominated by the military, to one in which the civil customer is playing an ever increasing role. As part of this change there is an increasing demand for vehicles whose interior noise levels are substantially lower than those of their predecessors.

One of the most significant recent events in the area of helicopter noise has been an impending regulatory action, rather than a technological breakthrough. This action is the development of helicopter noise standards which are currently being considered simultaneously by the International Congress of Aeronautical Organizations (ICAO) and by the Federal Aviation Administration (FAA) in the United States. Up to the present time the specification of external noise limits, if any, were either made by individual customers, based on a particular need, or by the designer and manufacturer who might try to forecast how noisy the aircraft could be and still meet market requirements. It is highly probable that the effect of the new standards will be to require future helicopters to be substantially quieter than many of the current models.

The noise measurement unit which has been proposed, Effective Perceived Noise Level (EPNL), is the measure used for regulating jet airplanes. Because of the particularly unique characteristic of rotor noise, which under some conditions may become highly impulsive, there is consideration being given to developing

an extra penalty based on some measure of impulsiveness such as crest factor. The necessity for such a correction is still under investigation and may, in fact, be academic with respect to the development of new helicopters, because the manufacturers are well aware that helicopters with impulsive acoustical signatures are no longer acceptable to either the military, because of detection, or to the civil operator who must fly over populated areas.

Interior noise in helicopters is also coming under more critical consideration by the operator and passenger. As part of its Civil Helicopter Program, NASA operated a large passenger carrying helicopter on a tour of the United States. At each city demonstration rides were given to many individuals who then filled out a survey giving their reaction to the flight. Tabulation of the surveys⁽¹⁾ revealed that internal noise in the airliner type cabin was the source of greatest passenger complaint. In order to compete with alternative modes of transportation, smaller civil helicopters will have to provide the passengers with levels comparable with

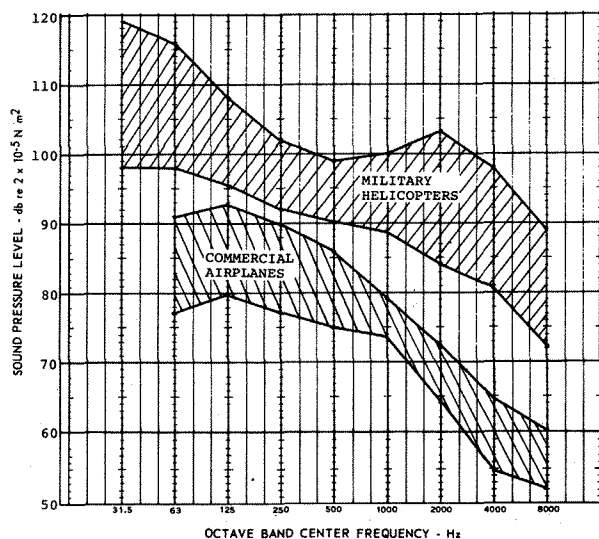

FIGURE 1. COMPARISON OF INTERIOR LEVELS - MILITARY HELICOPTERS AND COMMERCIAL AIRPLANES

business airplanes and the larger ones comparable with airliners. Figure 1 compares the range of levels measured in several military helicopters with those required to satisfy the civil customer, and illustrates the challenge in meeting the requirements of this rapidly growing market.

Components of Helicopter Noise

Main Rotors. The aerodynamic environment of the helicopter main rotor is an extremely complex one (Figure 2).

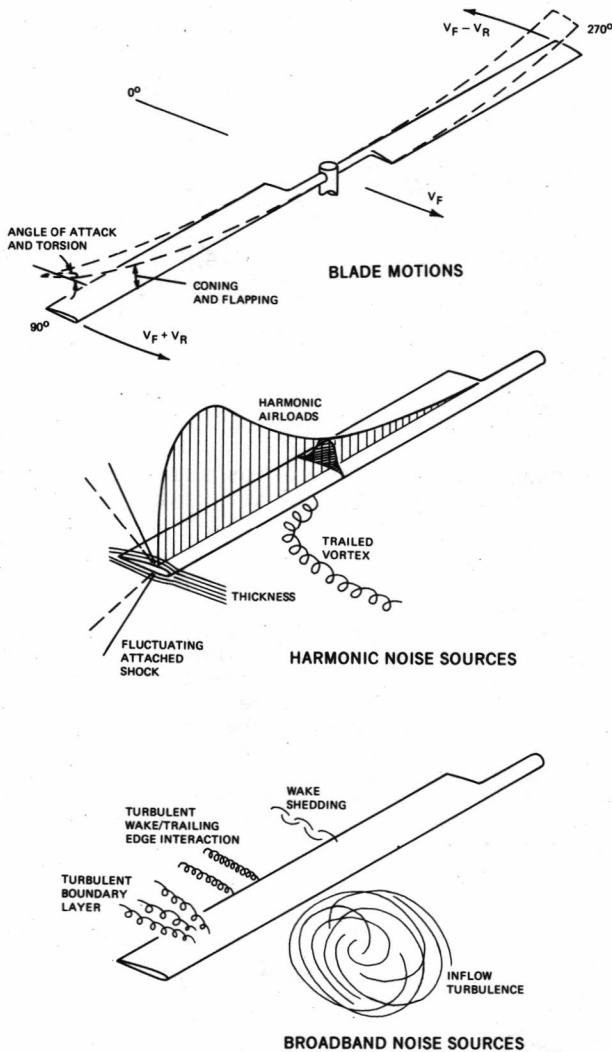

FIGURE 2. AERODYNAMIC SOURCES OF ROTOR NOISE

The complexity is inherent in the fundamental principles of the rotary wing which has a linearly varying velocity along the radius of the blade which is superimposed on the forward flight velocity of the aircraft, and produces a resultant velocity which varies with a once per rotor revolution time base. This situation is

further complicated by the fact that control inputs cause the angle of attack of the blade to vary around the azimuth. Since the blade is also twisted along its length the net result is a time varying velocity and airloading which differs at each radial station. Another very important aerodynamic influence is that caused by the trailed vortex from the blade tip which may come very close to, or even be intersected by a following blade resulting in sudden large changes of effective angle of attack. Figure 3 shows the tip vortices which have been made visible by smoke generators at the blade tips.

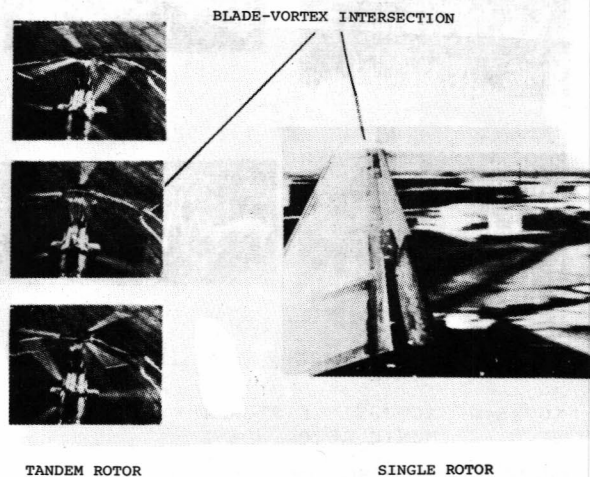

FIGURE 3. EXAMPLES OF BLADE-VORTEX INTERSECTIONS

This situation can occur either on tandem rotor helicopters where the interaction generally occurs between a vortex trailed from a forward rotor blade and a blade on the aft rotor, or on single rotor helicopters in descent (or in some conditions in hover) when the interaction is between the vortex shed by one blade and the following blade on the same rotor. More complete discussions of these phenomena can be found in several papers. (2,3,4)

The noise sources which can arise from the aerodynamic loadings on a rotor blade are under continuous study, and new ones seem to be identified as researchers get more deeply into the problem. An excellent comprehensive review can be found in Reference (5). The sources can be grouped into two distinct categories; those which produce harmonic noise, and those which produce broadband noise.

Harmonic noise arises from the lift loads, at all airspeeds; from blade-vortex interaction, when it occurs; and from high advancing tip speed effects (build up and collapse of the attached shock, and thickness effects on the advancing side).

Figure 4 presents typical narrow band spectra and wave forms corresponding to each of these harmonic noise sources.

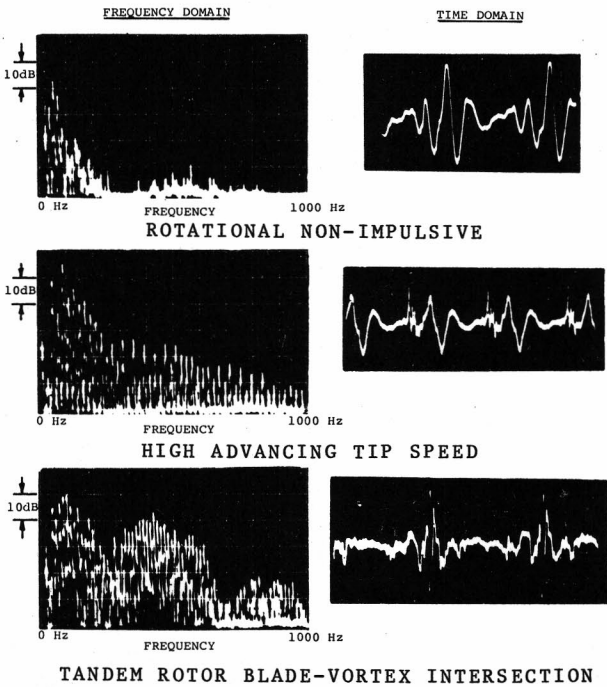

FIGURE 4. ACOUSTICAL SIGNATURES OF HARMONIC ROTOR NOISE

Broadband noise sources are much more difficult to separate. Some of the contributors include: noise due to turbulent inflow (either from the atmosphere or the rotor system itself); interaction between the boundary layer on the blade and the sharp trailing edge; the tip vortex, and radiation due to vortex sheet shedding at the trailing edge. This last condition, which occurs only within a certain range of Reynolds numbers, is really quasi-broad band in that it should be a discrete frequency for a given airfoil velocity. Since the frequency is velocity dependent, however, the continually varying blade section speed-radius-azimuth relationship previously discussed presents a spectrum which appears to be broadband in nature. The relative levels and importance of each of these sources may vary with helicopter configuration, detail design, and operating conditions. Much work is still being done in separating and identifying the sources.

Figure 5 displays typical one-third octave band spectra for a rotor operating under conditions which produce impulsive noise. Also shown are the corresponding Noy values. These are the frequency and amplitude weighted numbers which are used in the Perceived Noise Level calculations. Note that for the non-impulsive components the broadband noise will determine the PNdB level, while in the case of the impulsive rotor the harmonics become the driving factor. Furthermore, since the

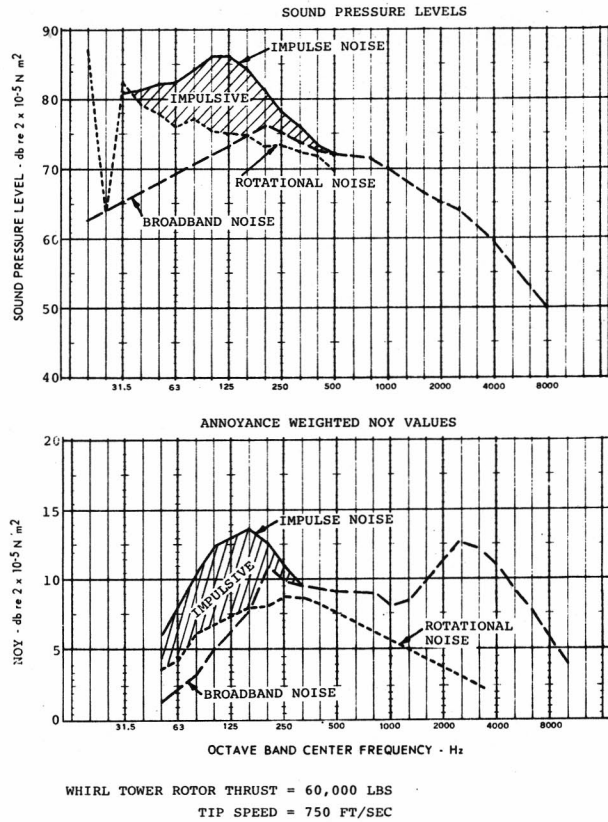

FIGURE 5. COMPARISON OF OBJECTIVE AND SUBJECTIVE MEASUREMENTS OF ROTOR NOISE

impulsive noise tends to become maximum in the plane of the rotor, while the broadband noise tends to be maximum more directly underneath, the high level of an impulsive rotor will precede the aircraft for a much greater time than will the sound of a non-impulsive rotor (Figure 6) further contributing to high values of Effective Perceived Noise Level since this measurement considers duration as well as amplitude.

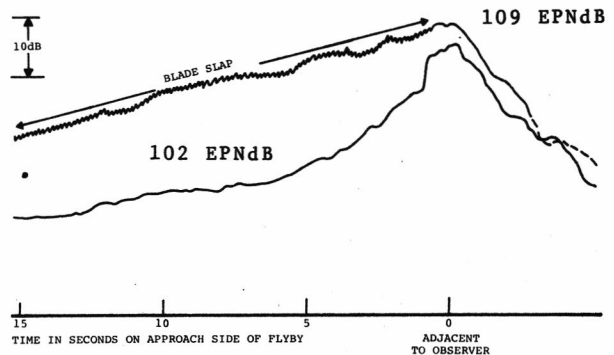

FIGURE 6. THE EFFECT OF IMPULSIVE ROTOR NOISE ON TIME DURATION

Tail Rotors. Tail rotors, on single rotor helicopters, are subject to many of the same load and noise variations as main rotors. In many cases the inflow environment for tail rotors is even worse than for main rotors because of impinging wake from the fuselage and the downwash environment from the main rotor. This latter influence can cause tail rotors to generate impulsive noise at the main rotor passage period due to interaction between the tail rotor blades and the main rotor tip vortex.

Engines. Modern helicopters are, for the most part, powered by turbo-shaft engines. Since the exit velocities of this type of turbine is quite low, broadband and discrete frequency inlet noise, along with core noise, are the only components which need to be considered. A recent study which was conducted for NASA⁽⁶⁾ concluded that, with the possible exception of future very large helicopters, broadband rotor noise, in the far field will dominate broadband engine noise. This means that the only engine noise treatment which may be required will be that for pure tones due to the compressor.

Transmissions. In most helicopters the transmissions are the major source of internal noise. These highly loaded, light weight, gear boxes are usually located directly over, or at the end(s) of the passenger compartment. Figure 7 is the narrow band spectrum measured inside a transport helicopter and clearly shows the dominance of the gear mesh frequencies, and their harmonics, over the other sources.

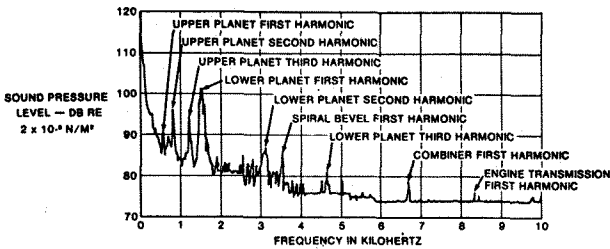

FIGURE 7. INTERNAL NOISE SPECTRUM - TRANSPORT HELICOPTER

Noise Reduction and Control

Rotor Noise

Tip Speed. There is little question that the most powerful single aspect of the helicopter which determines noise level is the rotor tip speed. This one parameter adversely affects almost every noise component generated by the rotor. Figure 8 compares the levels of several current helicopters with a preliminary version of a proposed limit. Even though these aircraft encompass a considerable size range, there is little likelihood that tip speeds much above 700 feet per second can be permitted, and, irrespective of tip speed, rotor impulse will have to be eliminated.

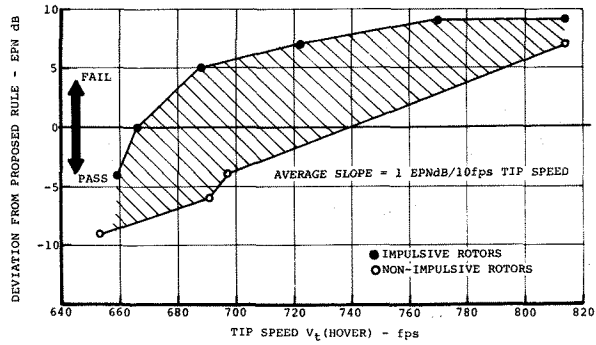

FIGURE 8. POTENTIAL IMPACT OF NOISE RULE ON DESIGN TIP SPEED

The problems associated with reducing tip speeds are multiple. In order to maintain the desired lift capability, for a given airfoil, the amount of blade area will have to be increased as the square of the decrease in tip speed. This can be achieved by increasing the number of blades, or the blade chord, both of which increase the weight of the rotor system. An even more drastic weight increase associated with lower rotor speeds is the increase in rotor torque, and hence shaft and transmission size. Figure 9 is a weight trend which illustrates this point.

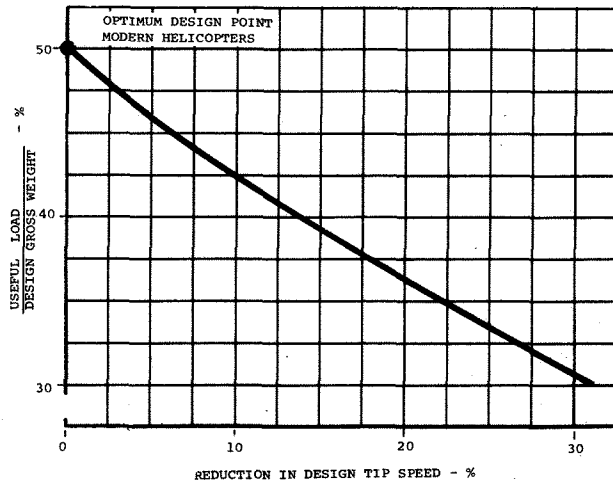

FIGURE 9. EFFECT OF ROTOR TIP SPEED ON USEFUL LOAD

Even if one is willing to pay the weight penalty associated with lower tip speeds there are important safety considerations to be observed. Foremost is maintaining high kinetic energy of the rotor which is required for the autorotative capability necessary to perform safe landings in case of engine failure. In addition, if tip speeds become too low the blade may stall on the retreating side resulting in high control system loads and airframe vibration levels.

Airfoils. The development of improved performance airfoils has been greatly aided by the introduction of new materials and manufacturing processes for rotor blades (such as the all fiberglass blade) which permit variation in airfoil along the blade span. Some of the newer designs employ as many as three airfoils to optimize the low speed inboard region, the mid-span portion, and the high speed tip area.

It has been demonstrated that in hover the vortex shed by a blade tends to remain in the plane of the rotor, or even rise above it, until the passage of the following rotor blade forces it downward. Therefore it follows that these vortices come very close to (or are intersected) by a following blade. The same studies indicated that impulsive noise, due to these interactions, occur only when the blade is operating above its shock stall boundary and that direct intersections, at conditions within the limits, did not produce excessive impulsive noise. This data is illustrated in Figure 10.

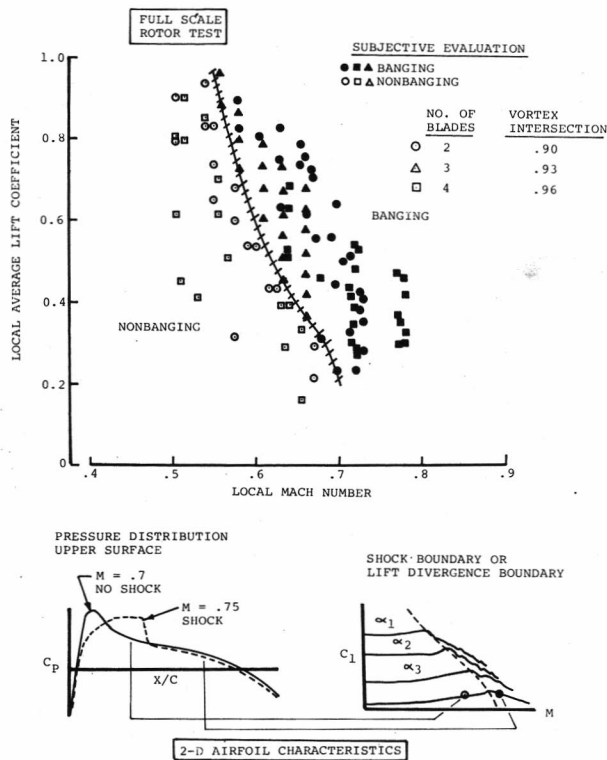

FIGURE 10. DEVELOPMENT OF SINGLE ROTOR BANG CRITERIA

The hypothesis is that when operating above shock stall there exists an attached, but unstable attached shock whose position can be caused to fluctuate by disturbances such as proximity to a vortex, or even a strong wind gust. Since the stall limit is a function of airfoil shape the proper

selection of airfoil can be most beneficial in alleviating noise. Figure 11 compares the 'bang free' operating limits of an older cambered airfoil with a newer one which was designed to control noise.

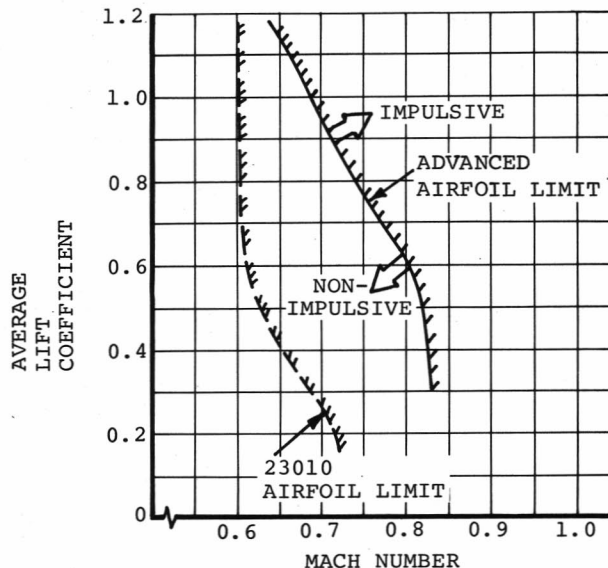

FIGURE 11. EFFECT OF AIRFOIL ON SINGLE ROTOR BANG BOUNDARIES

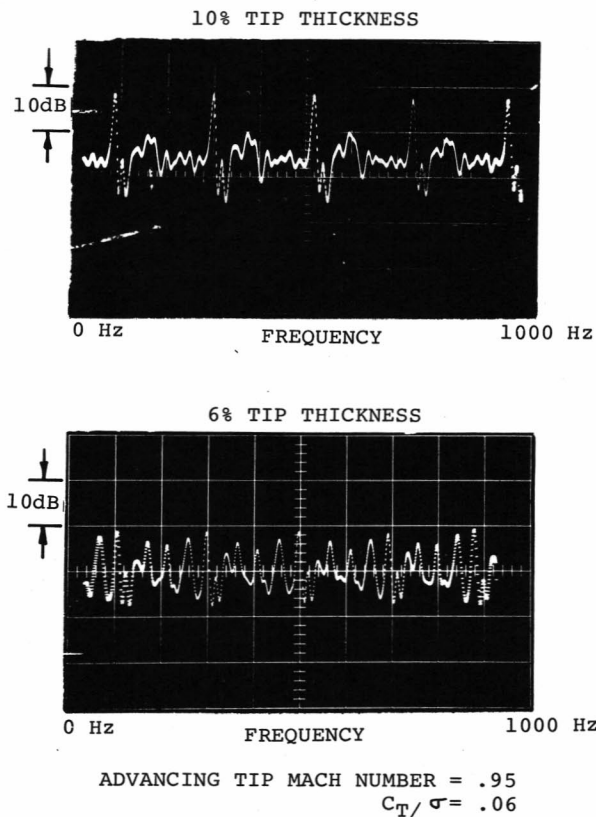

FIGURE 12. EFFECT OF TIP SHAPE ON HIGH TIP SPEED WAVEFORM

Tip Design. The blade tip is a particularly important region with respect to noise generation for two separate reasons: first, because it operates in the high-speed transonic flow regime, and secondly, because it is the area which generates the tip vortex.

The aerodynamics associated with high tip speed noise generation due to the advancing tip shock variation and also due to thickness noise have been described in a recent paper (7). Regardless of the physics of origin the two most effective controls are low tip speed and the use of thin airfoils. Figure 12, from model tests, clearly shows the improved acoustical signature which can be achieved at high Mach numbers due to the use of a thin airfoil at the tip.

The results of full scale flight testing (Figure 13) illustrate that at lower advancing tip speeds the thin tip offers no particular advantage and that the same is true at very high speeds where the limits of both tips have been exceeded. The delay in onset of impulsive noise buildup between these two limits, however, is very significant because it generally occurs in the forward speed range of 150 to 170 knots where many modern helicopters operate.

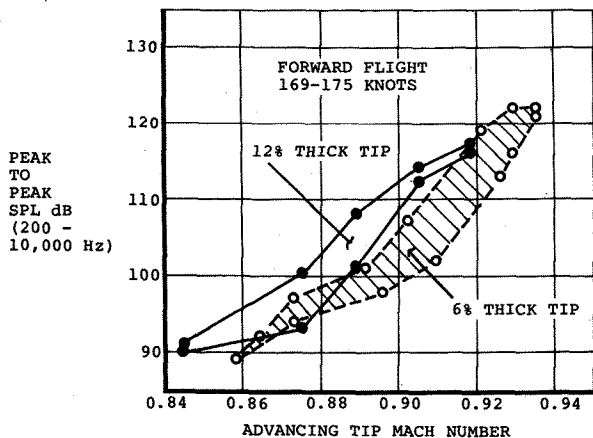

FIGURE 13. EFFECT OF TIP THICKNESS ON ROTOR NOISE

The other control which has been attempted by tip design is restructuring of the shed vortex core, either into multiple weaker vortices, or one with a larger diameter core with lower maximum induced velocities. Of the many tip shapes which have been tried one of the more promising is a recent development by the U.S. Army and NASA jointly at the NASA Langley Research Center (8). This shape, called the Oggee tip has a planform which approximates the contour of the zero differential pressure line. Reasonable success has been demonstrated in reducing the impulsive noise of a single rotor in descent (Figure 14).

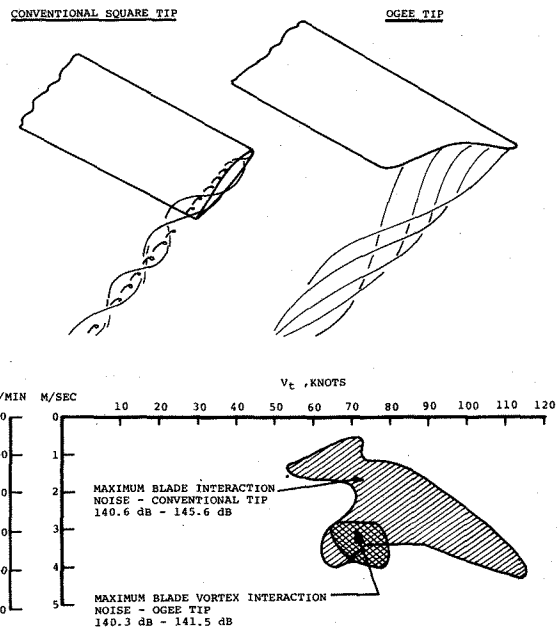

FIGURE 14. EFFECT OF OGEE TIP ON ROTOR BANG BOUNDARIES IN DESCENT (From Reference 10)

There is at the present time, however, little unanimity regarding optimum tip shape except that it should be thin.

Another, more radical, approach which is being investigated is one in which air is injected into the vortex core through a chordwise slot at the blade tip (9). Helium bubble tests with a non-rotating model show that a very moderate mass of injected air can almost completely dissipate the vortex core. Additional testing, including measurement of noise on rotating models is continuing at the NASA Langley Research Center.

Blade Elasticity. Figure 15 presents the results of an analytical study which may have some, as yet untested, implications about the role which blade stiffness may be able to play in controlling noise.

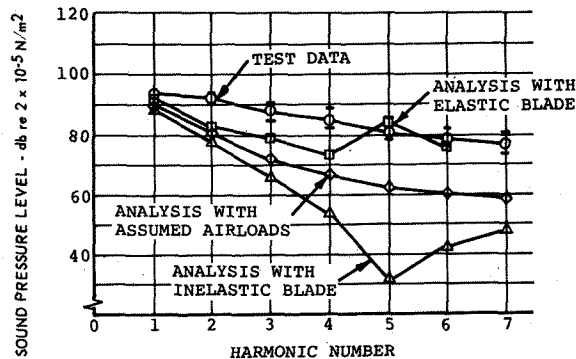

FIGURE 15. EFFECT OF BLADE STIFFNESS ON ROTOR NOISE

The figure shows flight test result of a helicopter with a fiberglass blade. Also shown are the analytical predictions which were performed using three different sets of airloads as input. The first set was from an analysis which assumed an infinitely rigid blade, the second assumed a torsional stiffness comparable with older steel spar blades, and the third using the best available actual stiffness data. Note that although the blade torsional stiffness has little effect on the first few harmonics the agreement with higher harmonic data improves as the torsional stiffness more closely approximates the proper values.

Rotor Placement. Earlier designs of tandem rotor helicopters developed highly impulsive signatures in forward flight, due to intersections between forward rotor tip vortices and aft rotor blades. Vortex visualization studies along with noise measurements conducted on a CH-46 helicopter provided the separation criteria shown in Figure 16.

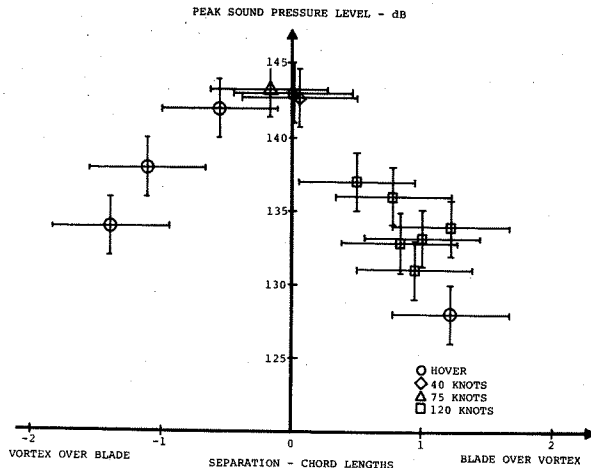

FIGURE 16. EFFECT OF BLADE-VORTEX SEPARATION ON TANDEM ROTOR BANG

The effect of implementing these criteria can be seen in Figure 17 which shows test results which were obtained by modifying a CH-47 helicopter by raising its aft rotor 30 inches.

It can be expected that tandem rotor helicopters of the future will have higher aft pylons; and probably less rotor overlap than their predecessors.

Transmission Noise

As discussed previously, transmission noise is the primary contributor to the interior acoustical environment of most helicopters. Until recently most attempts to control this noise were mainly directed at the acoustical treatment of the fuselage, with relatively little attempt at quieting the transmission itself. A con-

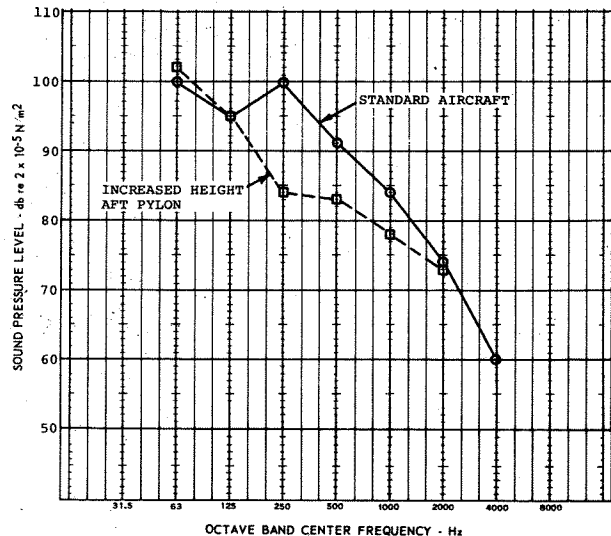

FIGURE 17. FLIGHT TEST RESULTS - TANDEM ROTOR HELICOPTER WITH INCREASED BLADE-VORTEX SEPARATION

structive contribution⁽¹⁰⁾ was made by the staff at Mechanical Technologies Inc. who suggested that there might be a strong relationship between the dynamic response characteristics of a transmission and the noise generated by it. The source of dynamic input was hypothesized to be torsional oscillations due to the fact that, with any finite contact ratio, the load is shared by different numbers of teeth at different times during the load cycle. Since the spring constant of the gear teeth is of course constant, the deflection will vary inversely with the number of teeth in contact at a given time thus causing both torsional oscillation and bending of the gear shafts at the tooth contact frequency. It was further hypothesized that the key parameter in determining noise was the displacement across the bearings which would transmit the vibrations from the rotating system to the stationary case, from which they could radiate to the structure and air as noise.

Verification of this idea was carried out by the Boeing Vertol Company⁽¹¹⁾ through a test program which was conducted in a load stand on a highly instrumented CH-47 rotor transmission. Simultaneous measurements were made of gear shaft torsion and bending, displacement across the bearings, transmission case vibration, and radiated noise. Results such as those shown in Figure 18 verified the orderly traceability from shaft vibration to noise.

The data also indicated that the response of the rotating dynamic system was predictable by a finite element (NASTRAN) type of analysis if coupling between bending and torsion modes and coupling between the separate gear shafts were considered. Figure 19 illustrates the detail in which a transmission consisting

of a spiral bevel input with a two stage planetary gear system output must be modeled in order to obtain good agreement with data. Some of the more difficult input parameters to define are the stiffness of the gear teeth and bearings.

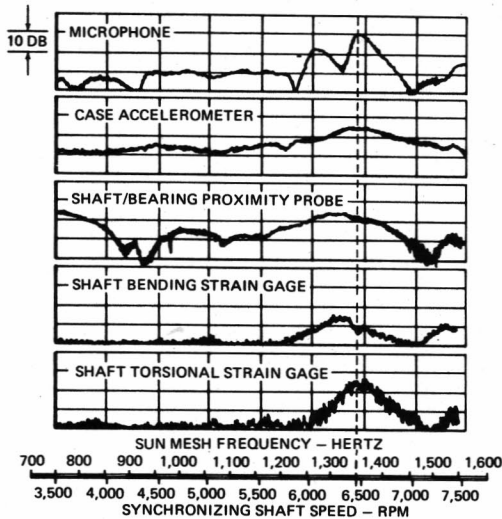

FIGURE 18. PROPAGATION OF SUN GEAR MESH EXCITATION

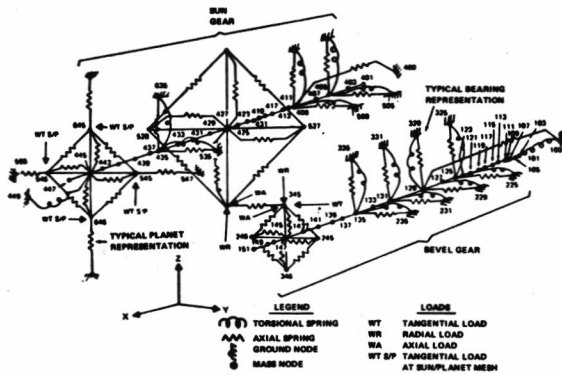

FIGURE 19. NASTRAN MODEL OF ROTOR TRANSMISSION COMPONENTS

That such an analysis can be made to work is demonstrated in Figure 20 which compares the calculated mode shape of the spiral bevel input gear, responding to its own mesh frequency, with the measured displacement at the two support bearings. As important as the magnitude prediction is the agreement in phase relationship between calculated and measured data which indicates the identification of the proper mode.

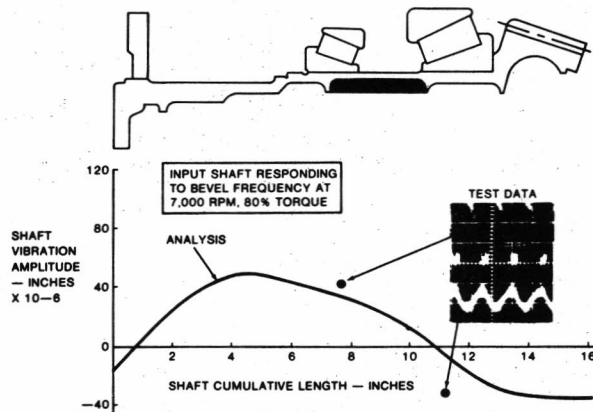

FIGURE 20. MODE SHAPE CORRELATION-BEVEL GEAR

The true value of such an analysis lies in its ability to examine proposed designs and to alter them, if necessary, in order to design quieter transmissions. Figure 21 shows the results of an analysis of the sun gear and indicates high displacement at one of the two bearings. Analytically stiffening the shaft by adding the material shown in the darkened area of the figure resulted in a pronounced reduction of this displacement and hence an improved design.

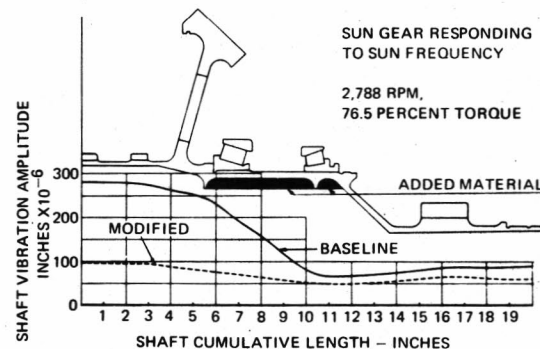

FIGURE 21. REDESIGN OF GEAR RESULTING FROM DYNAMIC ANALYSIS

In a similar manner it should be able to model the transmission case. This turns out to be even more complex than the dynamic parts due to extreme lack of symmetry and uniformity of shape. At the present time the rules for constructing a good finite element model of the type shown in Figure 22 are not well defined and perhaps may be considered almost as much of an art as a science. Key elements of consideration, however, include the tradeoff between element size and computer running time (which can easily become excessive) and the rigidity, or fixity, which is assigned as end conditions for the mechanically fastened parts.

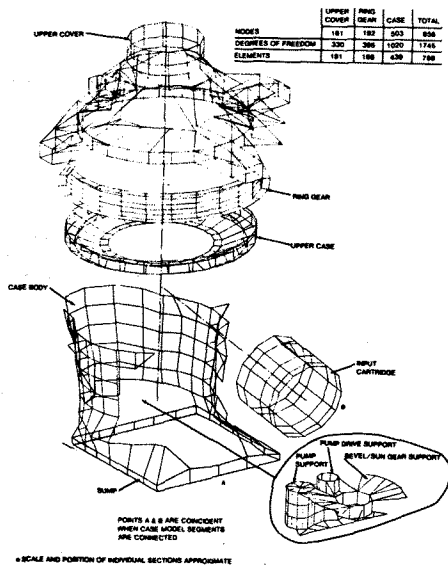

FIGURE 22. NASTRAN MODEL OF TRANSMISSION CASE

The successful application of these techniques has been recently demonstrated, however, by a program in which a modified sun gear and stiffened transmission case resulted in a 7dB noise reduction.

References

1. Snyder, W.J., and Schultz, M.B.: Civil Helicopter Flight Research, AIAA Paper 77-896, September 1976.
2. Spencer, R.H.: Application of Vortex Visualization Test Techniques to Rotor Noise Research, American Helicopter Society Preprint No. 470, June 1970.
3. Sternfeld, H.: Influence of the Tip Vortex on Helicopter Rotor Noise, AGARD Conference Proceedings No. 22, September 1967.
4. Cox, C.R.: Helicopter Rotor Aerodynamic and Aeroacoustic Environments, AIAA 4th Aeroacoustics Conference Preprint 77, 1338, October 1977.
5. George, A.R.: Helicopter Noise--State of the Art, AIAA 4th Aeroacoustics Conference Paper 77-1337, October 1977.
6. Sternfeld, H. and Doyle, L.: The Effects of Engine Noise and Rotor Broadband Noise on Civil Helicopter Operations, NASA CR 145085,
7. Schmitz, F. and Yu, Y.: Theoretical Modeling of High Speed Helicopter Impulsive Noise, Third European Rotorcraft and Powered Lift Aircraft Forum, September 1977.
8. Mantay, W.: Full Scale Testing of an Ogee Tip Rotor, Specialists Meeting on Helicopter Acoustics, Hampton, VA, May 1978 (To Be Published).
9. White, R., Jr.: The Status of Rotor Noise Technology--One Man's Opinion, Specialists Meeting on Helicopter Acoustics, Hampton, VA, May 1978 (To Be Published).
10. Badgley, R.: Reduction of Noise and Acoustic Frequency Vibrations in Aircraft Transmissions, Preprint 661, 28th Annual Forum of the American Helicopter Society, Washington, D.C., May 1972.
11. Hartman, R.: A Dynamics Approach to Helicopter Transmission Noise Reduction and Improved Reliability, Preprint 772, 29th Annual Forum of the American Helicopter Society, Washington, D.C., May 1973.